

CAD FILE:

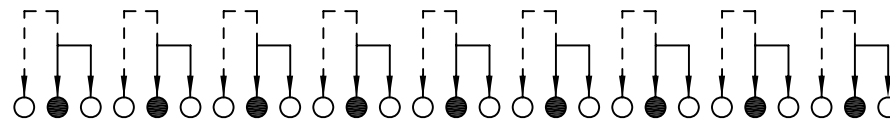

SCHMATIC (SHORTING)

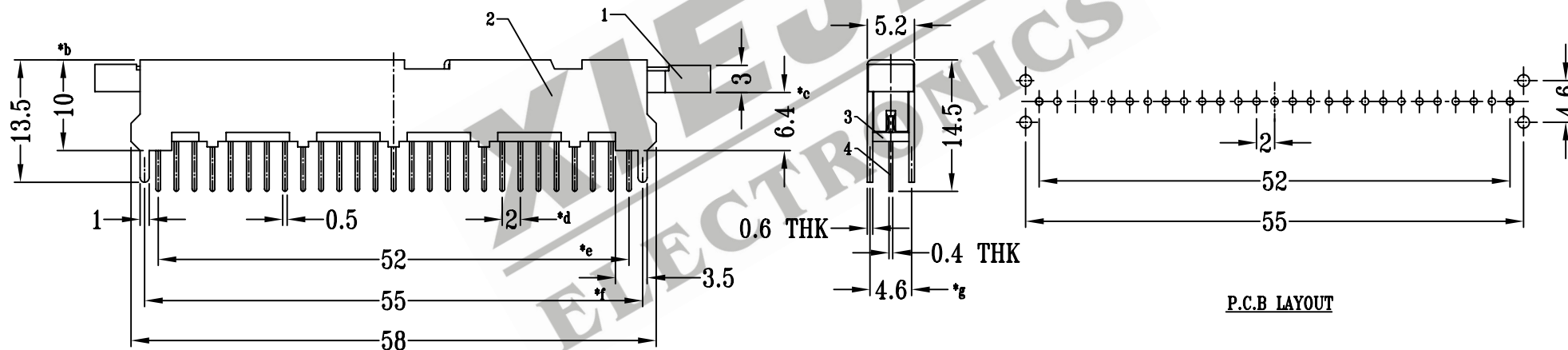
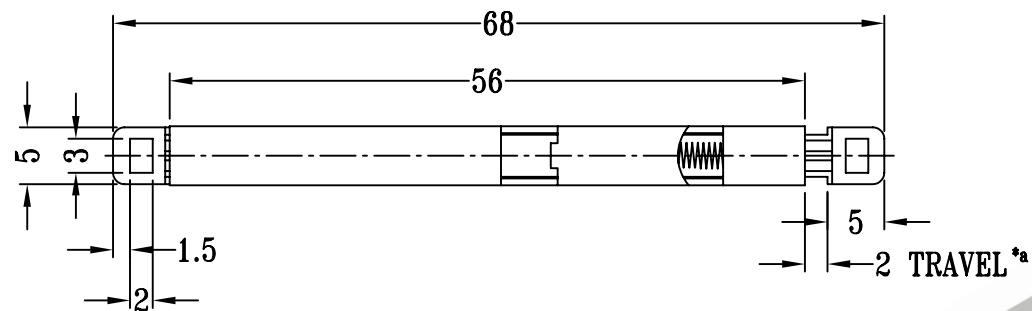

P.C.B LAYOUT

注:带*表示关键尺寸(7个)

				TOLERANCE UNLESS SPECIFIED		SHENZHEN XIEJIA ELECTRONICS CO.,LTD.				
				WITHIN : 1.5±0.1mm		ISSUE	DATE	DESCRIPTIONS OF REVISION		APPD.
				OVER : 1.5±0.2mm						
8										
7										
6	SPRING	STEEL WIRE	1	TEMPER						
5	CONTACT CLIP	PBS	9	Ag PLATED						
4	TERMINAL	BRASS STRIP	27	Ag PLATED OVER Ni PLATED	TITLE : PUSH SWITCH		UNIT : mm	DRWG NO.: XJ-DR-PS92D04-00		
3	BASE	PHENOLIC RESIN	1	NATURAL	MODEL: PS-92D04		SCALE: 3:2	DWN.	ZHOUYU	2005-4-17
2	FRAME	STEEL STRIP	1	Ni PLATED				CHK'D	FANGYING	2005-4-17
1	KNOB	ABS/PC	1	BLACK	ALL MATERIALS MUST BE COMPLIANT TO ROHS			APPD.	KANGXINAN	2005-4-17
NO.	PARTS	MATERIALS	Q'TY	FINISH						